

66-20 weigh module

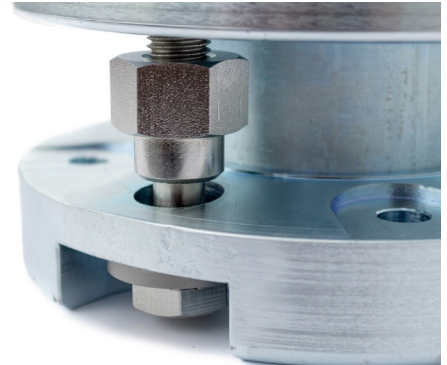
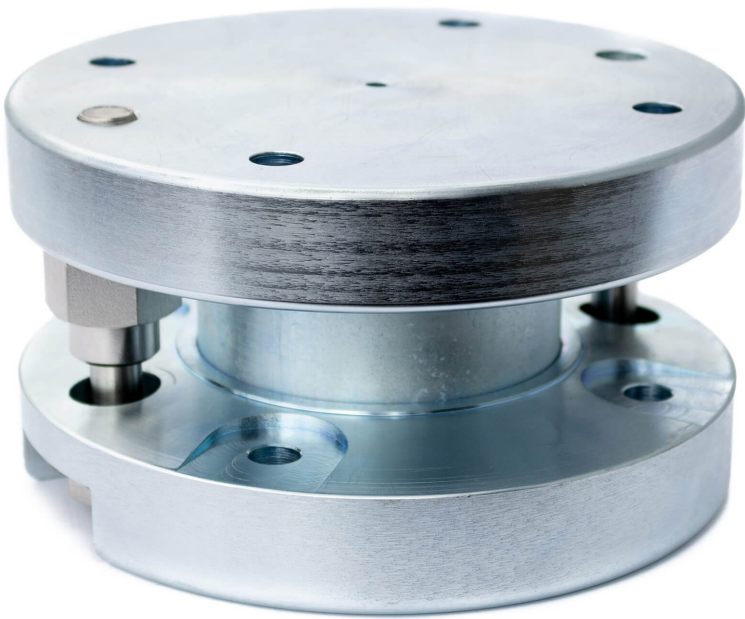

product description

The 66-20 weigh module has been designed for use with the Q50 compression load cell in food and pharmaceutical applications.

Constructed from plated alloy steel or electro-polished stainless steel it is ideally suited to CIP (Clean-in-Place) and SIP (Sterilization-in-Place) environments.

The weigh module provides system integrators with a uniform, compact and economical solution across a wide range of load cell capacities – from 500kg through to 30,000 kg.

applications

Tanks and vessel weighing systems.

key features

Capacities of 0.5t to 30t

Alloy steel or stainless-steel construction

Low profile design

Easy to install and clean

Specially designed for hopper and tank weighing

Integrated lift-off protection

Load cell replacement requires minimum lifting height

accessories

Welding fixture

RoHS
compliant

 **flintec**

product dimensions (mm)

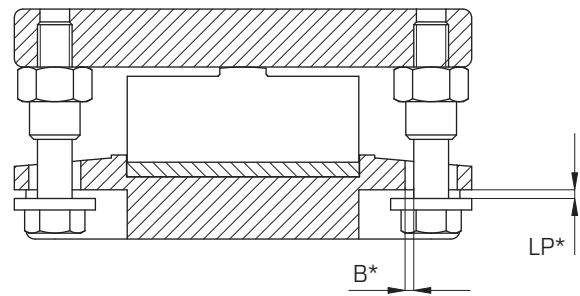
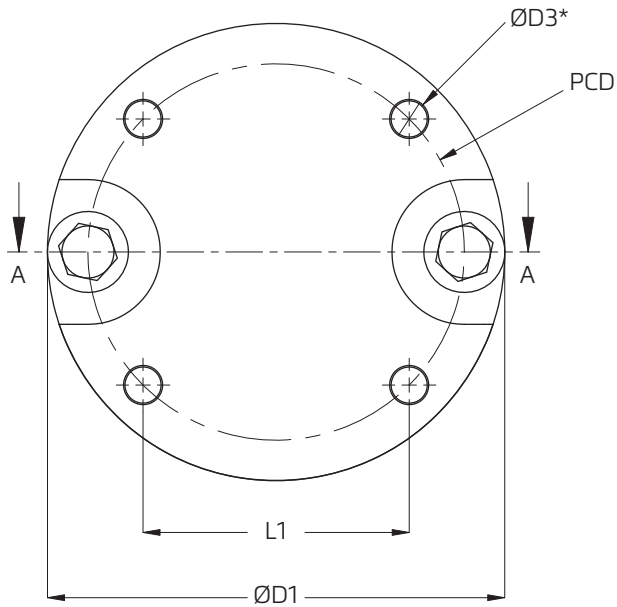

key

- ØD3* - 8xD3 (for bolt size T1)
- LP* - Lift off protection gap of 2 to 3mm
- LC* - Load center
- B* - Bumping gap, equal in all directions

attention

Mounting bolts are not included in delivery
 Load carrier and foundation plate to be horizontal:
 - within 0.8/100 for general applications
 External bumper stops are required.

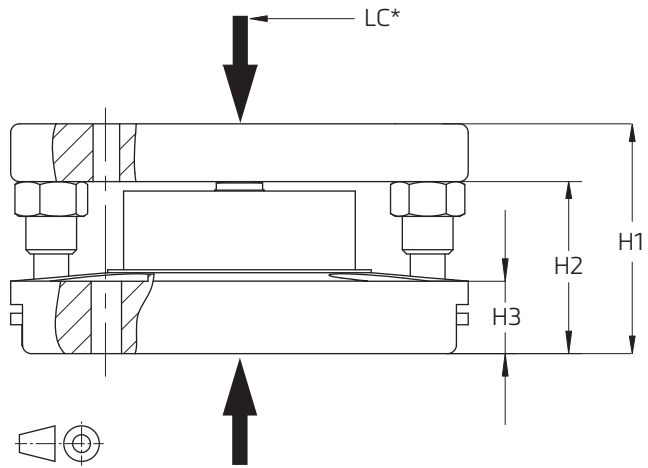

Weigh Module Type	Capacity	D1	D3	H1	H2	H3	PCD	L1	T1	B (±)	Max liftoff force (t)	Weight excl. load cell (kg)
66-20	500kg ... 5t	158	13	79.5	59.5	29	130	92	M12	4.1	2.5	7.9
	10t	188	13	104	74	37	146	103	M12	4.75	2.5	13.1
	20t ... 30t	228	17	124	91.4	42	185	131	M16	6.25	4.5	21.4

Dimensions and specifications are subject to change without notice.